

921-9xx

Lv7 2019-r2

Modelo-model:

Oplus SR+

Lote-Lot-Lot-Lot:



Peso-Weight-Poids-Gewicht:

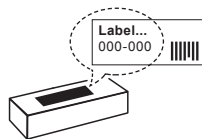

Max: 75 kg

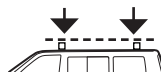

CEE - EEC type approval:

E₉ 26 R- 03 3016



CITY CRASH (↩)

CRUZBER SA
ES-A14018311
P.I. Las Salinas II
14960 - Rute - Spain
www.cruzber.com



- | | | |
|--------------|---|------------------------|
| (E) | Instrucción de montaje
¡Leer primero! | Barras de acero |
| (GB) | Assembly instructions
Read first! | Steel bars |
| (F) | Instruction de montage
Lire en premier! | Barres d'acier |
| (D) | Montageanleitung
Zuerst lesen! | Stahldachträger |
| (PT) | Instruções de montagem
Ler primeiro! | Barras d'aço |
| (PL) | Instrukcja montażu
Najpierw przeczytaj! | Belki stalowe |
| (CZ) | Montážní návod
Čtěte pozorně! | Ocelové střešní nosiče |
| (HU) | Szerelési Utasítás
Először olvasd el! | Acél rudak |
| (RO) | Instructiuni de montaj
Intai cititi! | Čelične šipke |
| (HR) | Detaljne upute
Prvo procitati! | Bare din otel |
| (GR) | Διαβάστε προσεκτικά τις
Οδηγίες Συναρμολόγησης! | Μπάρες Σιδερέ |
| (TR) | Öncelikle montaj:
Talimatlarını okuyunuz! | Çelik barlar |
| (RU) | Инструкции по монтажу
Сначала прочитайте! | Стальные поперечины |
| (I) | Istruzioni di montaggio
Leggere per primo! | Barre d'acciaio |
| (NL) | Montagehandleiding
Eerst lezen! | Stalen dakdragers |
| (SLO) | Navodila za sestavljanje
Preberite! | Jeklene prečke |

1.

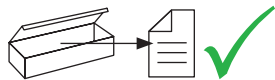

(E) Contenido embalaje: ¡Verificar!

x1

x1

(GB) Package content: Check!



(F) Contenu d'emballage: Vérifier!

(D) Packungsinhalt: Überprüfen!

x2

(PT) Contéudo embalagem:
Verificar!

(PL) Zawartość opakowania:
sprawdź!

(CZ) Obsah balení: Zkontrolujte!

(HU) Csomag tartalma: Ellenőrizd!

(RO) Pachetul contine: Verificati!

(HR) Sadržaj paketa: Provjeri!

(GR) Ελέγξτε το περιεχόμενο: του
πακέτου!

(TR) Paket içeriğini: Control ediniz!



(RU) Содержание упаковки:
Проверьте!

(I) Contenuto della confezione:
Controllare!

(NL) Pakket inhoud: Controleer!

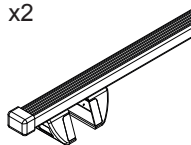
(SLO) Vsebina paketa: Preverite!

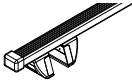

Código Code		↔		Lote Lot
921-932	SR+ 110	110 cm	4,05 kg	03/15
921-934	SR+ 120	120 cm	4,30 kg	03/15
921-936	SR+ 130	130 cm	4,55 kg	03/15
921-937	SR+ 135	135 cm	4,70 kg	04/15
921-938	SR+ 140	140 cm	4,98 kg	04/15
921-939	SR+ 150	150 cm	5,26 kg	03/15

2.



Importante!
Important!
Important!
Wichtig!

- E** ¡Las barras tienen que usarse con sistemas de railing de techo homologados por el fabricante del vehículo!
- GB** Bars must be used with roof rails certified by cars manufacturer!
- F** Les barres devront être utilisées avec des railing de toit certifiés pour le fabricant du véhicule!
- D** Die Dachträger müssen mit einer vom Autohersteller geprüften Dachreling verwendet werden!
- PT** As barras devem ser utilizadas com rail de tejadillo homologado por o fabricante do veículo!
- PL** Belki muszą być stosowane z relingami certyfikowanymi przez producenta samochodu!

- CZ** Tento nosič musí být používán pouze na hagusy, které jsou schválené výrobcem vozidla!
- HU** A rudak csak a gyár által minősített hosszanti korlátal használható!
- RO** Barele transversale, trebuie utilizate cu bare longitudinale, agregate de producătorul autoturismului!
- HR** Šipke moraju biti korištene sa krovnim nosačem koji je certificiran od strane proizvođača automobila!
- GR** Οι μπάρες της CRUZ πρέπει να χρησιμοποιούνται σε κάθετες εργοστασιακές μπάρες πιστοποιημένες από τον κατασκευαστή του αυτοκινήτου
- TR** Barlar, araç üreticileri tarafından onaylanmış tavan çataları ile kullanılmalıdır.
- RU** Поперечины должны быть использованы с рейлингами, сертифицированными производителем транспортного средства!
- IT** Le barre devono essere utilizzate unicamente con il sistema railing da tetto omologato dalla casa produttrice dell'auto
- NL** De dakdragers moeten worden gebruikt in combinatie met door de autofabrikant goedgekeurde dakrails!

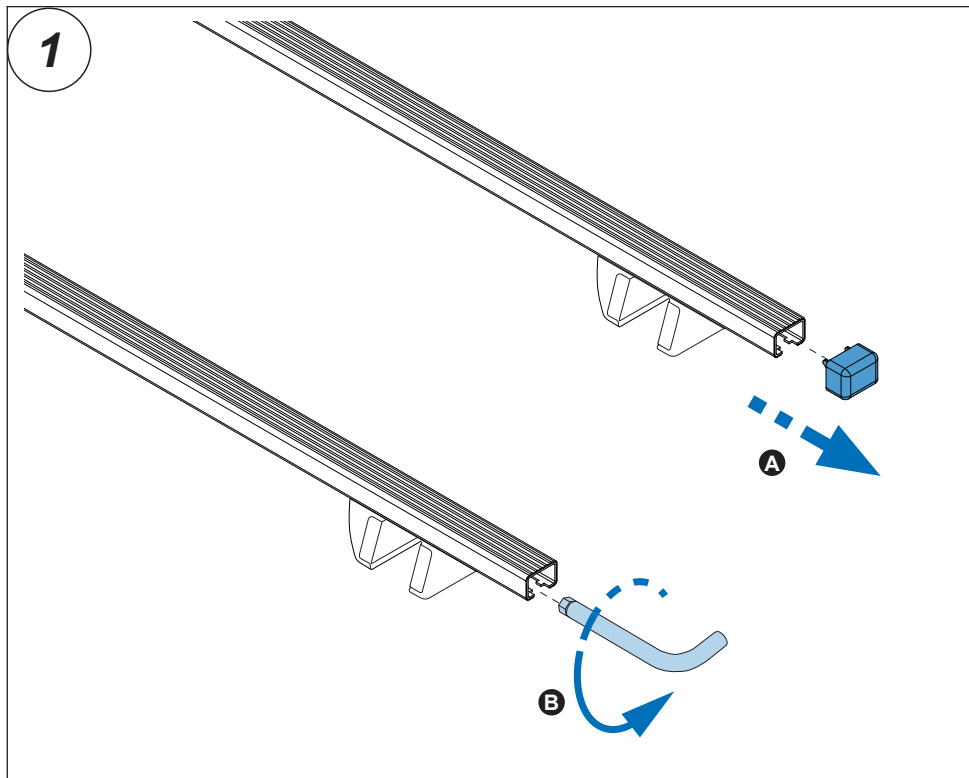

3. 

